

# INSTRUCTIONS MANUAL

# COD. 290



**Rowan Elettronica**  
*Motori, azionamenti, accessori e servizi per l'automazione*  
Via Fogazzaro, 67 - CALDOGNO - VICENZA - ITALIA  
Tel.: 0444 - 905566 (4 linee r.a.)  
Fax: 0444 - 905593 - E-mail: [info@rowan.it](mailto:info@rowan.it)



UNI EN ISO 9002  
27-03-1998

REV. 1 - Data 10/05/01

# COD. 290

## VARIABLE SPEED DRIVE FOR 3-PHASE ASYNCHRONOUS ROWAN MOTORS

### TECHNICAL CHARACTERISTICS

- Range of drives up to a power of max 30HP (23Kw)
- Standard voltage supply with possibility of selection 220/380VAC  $\pm 10\%$  50/60Hz; other voltages on request: 240 - 415 - 440 - 460
- Preset for controlling the speed of 2 - 4 - 6 pole ROWAN motors, equipped with tachometer generator of the type 10VDC/1400RPM
- Operating with linear acceleration and deceleration ramps
- Speed control by potentiometer 10Kohm connected with 2 or 3 wires or by reference from signal 0 ÷ +10VDC
- Input for torque control, which can be performed by means of external ROWAN cards (cod. 199 - cod. 232 or panel instruments cod. 249 and cod. 268)
- Input for RUN consent (AR) and stop consent with controlled deceleration ramp
- All input/output commands are galvanically separated from the power and can be controlled with PLC, programmable logics etc.
- Internal regulations: ACCELERATION AND DECELERATION RAMPS - MINIMUM SPEED - MAXIMUM SPEED - STABILITY
- Led visualizations of the following functions: POWER ON - MOTOR RUNNING - PHASE LACK - PRESENCE OF TACHOMETER GENERATOR
- Protections: phase lack, with output terminals for commanding an external emergency relay 24VDC max 50 mA. Fuses 0,5A for protecting control circuit
- Plug terminal board for input/output commands
- Operating temperature: -5°C +40°C
- Standard version in a container of aluminium IP 20; polycarbonate covering with useful indications for the checking and the setting.
- Cod.290/3, 290/4 and 290/5 have 1 or 2 ventilators according to the power and 1 termic-probe.

### MAX OVERALL SIZES (mm)

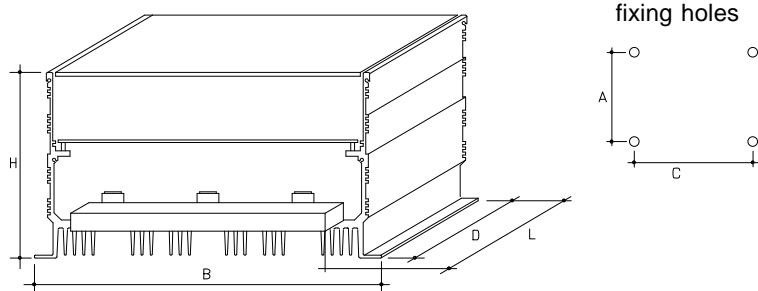

CODE	H	B	L	A	C	D
<b>290</b>	95	265	170	solo q. C	257	135
<b>290/1 - 290/2</b>	150	265	170	solo q. C	257	135
<b>290/3 - 290/4</b>	150	265	265	160	257	195
<b>290/5</b>	160	265	375	200	257	280

- For cod. 290, 290/1 e 290/2 the fixing holes are two, placed in the middle of measure D
- Measure A is referred to side D
- Measure C is referred to side B

### OPERATING PRINCIPLE

The drive of the series cod. 290 is a 3 phase voltage regulator with tachimetric feedback, which uses controlled diodes (SCR) controlled by a phase partializing system.

The tension that controls the motor is the resultant of an analogic process, which keeps the speed constant by means of the differential control between the real speed, from the tachometer generator, and the setting of the potentiometer or external analogic signal.

The coupling with 3-phase ROWAN motors gives as a result a constant speed and torque system, which is extremely silent and uniform, from 0 to max motor speed. The choice of controlled diodes as power devices (they are also over-dimensioned) gives more guarantees and reliability in case of extra-voltage or extra\_current.

It is also possible to regulate acceleration and deceleration ramps according to the requirements of the device driven by the 3-phase ROWAN motor. The deceleration ramp functions only with the motor applied to move braking loads or irreversible systems; in case of inertial loads, it is necessary to use other kinds of drives (see cod. 280), as cod. 290 has no dynamic braking. By connecting one of the following interface cards, cod. 199 - cod. 232 - cod. 249 - cod. 268, to terminal 8, it is possible to perform a torque-speed combined control of a 3-phase ROWAN motor. This coupling is necessary when one wants to use a ROWAN motor as brake or static clutch with winders/unwinders.

## MICROSWITCHES - LEDS - TRIMMERS SERIGRAPHY

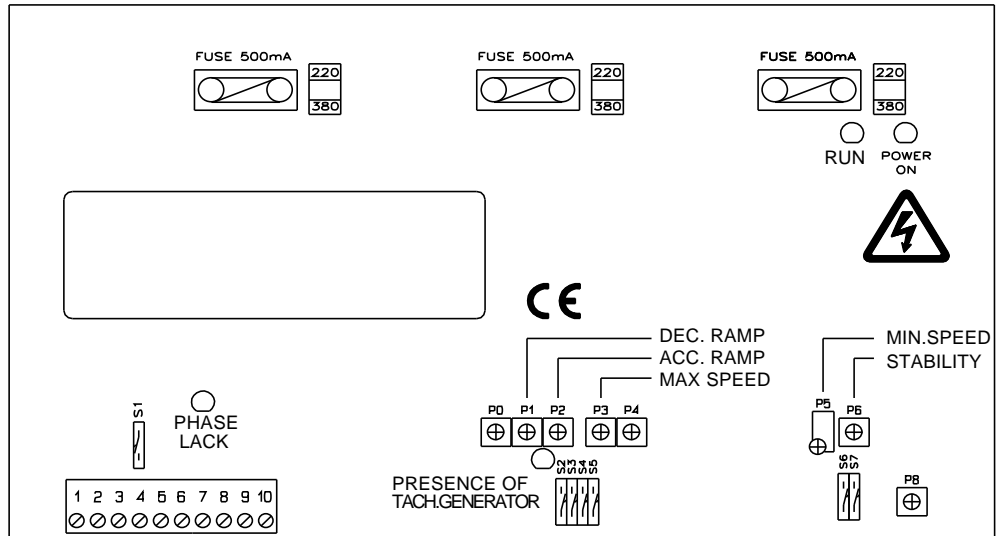

### TRIMMER DESCRIPTION:

- P1 DECELERATION:** it regulates the time of deceleration ramp in the following ranges:  
 with microswitch S2 open: min. 0,02 sec. - max 2 sec.  
 with microswitch S2 closed: min. 0,25 sec. - max 25 sec. Rotate clockwise to increase the time.
- 
- P2 ACCELERATION:** it regulates the time of acceleration ramp in the following ranges:  
 with microswitch S2 open: min. 0,02 sec. - max 2 sec.  
 with microswitch S2 closed: min. 0,25 sec. - max 25 sec. Rotate clockwise to increase the time.
- 
- P3 MAXIMUM SPEED:** it regulates the motor max speed with speed potentiometer set to max or with input +10VDC to terminal 6. Rotate clockwise to increase the speed.
- 
- P4 Revolution adapter 2/4 poles (AUTHORIZED PERSONNEL ONLY)**
- 
- P5 MINIMUM SPEED:** it regulates the minimum speed of the motor with speed potentiometer set to minimum or with input 0VDC to terminal 6. Standard regulation for 0 revolution. Rotate clockwise to increase the speed.
- 
- P6 STABILITY:** if rotated clockwise it lessens possible oscillations of motor speed due to rather unstable loading.

### CONTROL BOARD DESCRIPTION

- 1 - 2 Input for tachometer generator 10VDC/1400RPM.
- 
- 3 +10VDC max 10 mA reference for speed potentiometer supply.
- 
- 7 0V for analogue references
- 
- 4 - 7 Connection for STOP IN RAMP contact, closed it causes the motor ramp down to min. speed with controlled deceleration.
- 
- 5 - 7 Connection for A.R. (RUN consent) contact; open it enables the start of the motor with acceleration ramp, up to the max preset speed; it causes the lighting of led L1.
- 
- 3 Extreme Connection for speed potentiometer with 3 wires (microswitch S1 6 Cursor open); in this case it is possible to connect one or more 7 Extreme potentiometers in parallel up to a overall minimum resistance of 3Kohm between terminals 3 - 7.
- 
- 6 Extreme Connection for speed potentiometer with 2 wires (microswitch S1 7 Cursor closed); in this case it is possible to connect only one 10Kohm potentiometer.
- 
- 7(0V)-6(positive) Input for signal 0 ÷ +10VDC 2 mA for speed control by PLC or ROWAN interface cards.
- 
- 7(0V) - 8 Torque control input: for connection to ROWAN cards suitable for the automatic control of current with feedback from amperometric transformer. The cards to couple with are of type cod. 199 - cod. 232 or instruments cod. 249 and cod. 268.
- 
- 9 - 10 24VDC supply for the coil of relay of phase lack emergency max 50mA

## MICROSWITCH DESCRIPTION

- S1 Closed: It presets the connection for an external speed potentiometer with 2 wires to terminals 6 - 7.  
 Open : It presets the connection for an external speed potentiometer with 3 wires to terminals 3 - 6 - 7.  
 It presets the drive for speed control by D.C. signal  $0 \div +10V$ .
- 
- S2 Open : It selects the regulation range of acceleration and deceleration ramps min. 0,02 sec. max 2 sec.  
 Closed: It selects the regulation range of acceleration and deceleration ramps min 0,25 sec. max 25 sec.
- 
- S3 Open : It presets the drive for connection to a 2 pole motor.  
 Closed: It presets the drive for connection to a 4 - 6 pole motor. In case of a 6 pole motor, it is necessary to adjust the max speed with trimmer P3. With speed potentiometer set to max speed, or signal 10VDC, rotate P3 anticlockwise till one measures a D.C. voltage from tachometer generator of approximately 5,7VDC corresponding to a max speed of 800RPM.
- 
- S4 Closed They shut out the rectifying circuit of tachometer generator  
 S5 Open polarity. They particularly preset the drive to function in lifting equipments, coupled with card cod. 188.
- 
- S4 Open They activate the rectifying circuit of tachometer generator  
 S5 Closed polarity. They preset the drive to operate with the motor in the 2 rotation senses, with no necessity of inverting tachometer generator polarity.
- 
- S6 Open : It sets a speed variation from empty to full load of 0,1% as compared with motor maximum speed.  
 Closed: It sets a speed variation from empty to full load of 2% as compared with motor maximum speed.
- 
- S7 Closed: It activates a soft feedback and speeds up circuit response.

## VISUALIZATION DESCRIPTION

- L1 RUN: when illuminated, it indicates that the consent to motor rotation has been given by opening the contact A.R. between terminals 7 - 5
- 
- L2 POWER ON: illuminated when power is present on the drive and on control circuits.
- 
- L3 PHASE LACK: when ON in indicates:  
 - the absence of one phase from 3 phase power supply R1 - S1 - T1.  
 - the lighting of phase lack led statically removes the power from the motor (switching off of led L1 RUN) and energizes the emergency relay (if present) connected to terminals 9 - 10.
- 
- L4 TACHOMETER GENERATOR PRESENCE illuminated during motor rotation, it indicates the presence of voltage from tachometer generator on terminals 1 - 2.

## INSTRUCTIONS FOR THE CONNECTION WITH ROWAN MOTORS

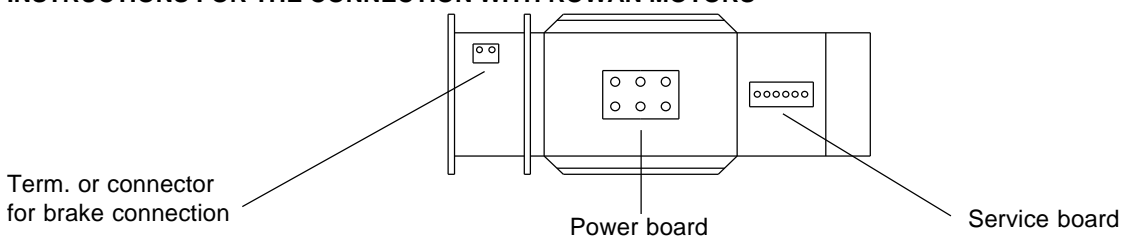

POWER BOARD CONNECTION: the connection, even if it passes through the drive, remains the same as that of a normal motor, therefore if on the motor you find:

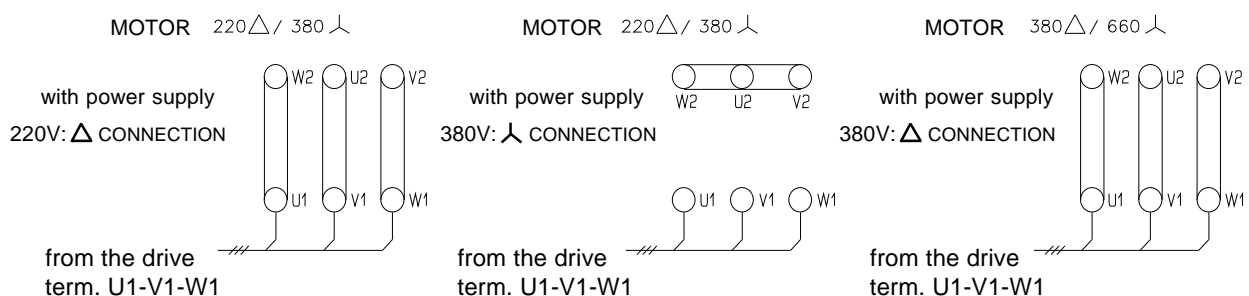

**RANGE OF POWERS OF DRIVES COD. 290  
FOR SPEED CONTROL OF 3-PHASE ROWAN MOTORS**

CODE	MAXIMUM POWER LINE 220 VAC		MAXIMUM POWER LINE 380 VAC (415-440- 460)		DELAY FUSES SUGGESTED	WEIGHT	FANS MOUNTED	THERMIC PROBE
	HP	KW	HP	KW	A	Kg	NR	NR
<b>290S</b>	2	1.5	4	3	20	1.9		
<b>290S/1</b>	6	4.5	10	7.5	40	3.4		
<b>290S/2</b>	7.5	5.5	14	10	50	3.5		
<b>290S/3</b>	17	12.5	30	22	100	4.3	1	1
<b>290S/4</b>	25	18.5	45	33	160	5.6	2	1
<b>290S/5</b>	40	30	70	51	250	6.5	2	1

**MOTOR SERVICE BOARD CONNECTION**

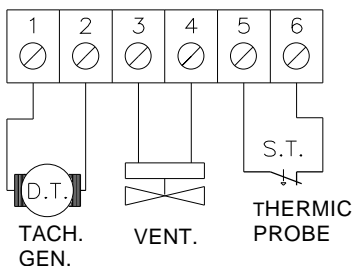

**1-2 TACHOMETER GENERATOR:**

from these terminals it is possible to have the voltage of the tachometer generator that is spliced to the motor shaft. It supplies a direct voltage of 20VDC at 2800RPM that is directly proportional to motor speed; for this reason, besides being connected to the drive for speed control, it can be used for analogic revolution counters, display counters or other servomechanisms, provided that the overall loading does not exceed 3K (max I 10 mA). It is always opportune, to avoid interferences, to connect the tachometer generator with screened cable, above all if cables are long and run close to power cabling.

**3-4 VENTILATOR:**

it is necessary to supply these terminals with 220VAC for the separated ventilation of motor; make sure that this voltage is present also when the motor is not running, in order to guarantee the max cooling efficiency. Some ROWAN motors of great power are equipped with 3 phase cochlea ventilators, which must be supplied directly at the base of the ventilator motor. As for the powers necessary for ventilators, see the table "3 phase motor characteristics".

**5-6 THERMIC PROBE**

it is a N.C. contact which opens when the temperature of motor windings exceeds 150°C, safety limit corresponding to H class (180°C). It is used as emergency for the switching off of RUN remote control switch. The max capacity of this contact is 1,5A - 250VAC.

**BRAKE CONNECTION:**

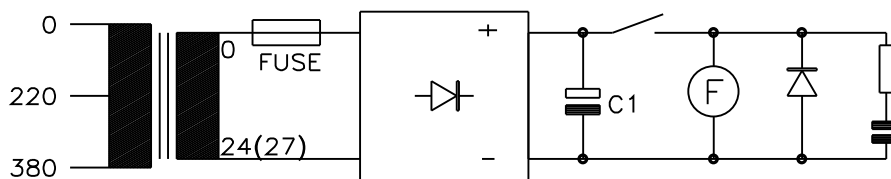

ROWAN motors can, on request, be provided with electromagnetic brake. In this case the motor must be constructed expressly with lengthened motor shaft and the brake is mounted on the front part, supported by a bell which reproduces the normal flanging conditions.

There are 2 different kinds of brakes:

**- DIRECT BRAKE:**

in this case it is necessary to supply the brake to block the motor shaft. This kind of brake is suitable for precision stops. Its efficiency can be increased by using ROWAN card cod. 210, which oversupplies it at the stop improving its precision.

**- SAFETY SPRING BRAKE**

in this case it is necessary to remove supply from the brake to block the motor shaft. It is used as safety brake in case of lack of main power supply, with suspended loads as overhead travelling cranes, cranes etc.

Both brakes operate with direct voltage 24VDC, and are supplied through the single terminal or connector placed on the front brake-bearing bell. It is always advisable to connect a diode or a R/C in parallel with the brake, above all when near to equipments that are particularly sensitive to disturbances.

**TABLE OF THE CHARACTERISTICS OF 24VDC BRAKES**

MOTOR	SPRING BRAKE		DIRECT BRAKE	
	TORQUE Kg/m	ABSORPTION <b>W</b>	TORQUE <b>Kg/m</b>	ABSORPTION <b>W</b>
<b>63</b>	0,4	20	0,75	11,5
<b>71</b>	0,4	20	0,75	11,5
<b>80</b>	0,8	25	1,5	16
<b>90</b>	1,6	30	3	21
<b>100</b>	1,6	30	3	21
<b>112 - 112L</b>	1,6 / 3	30 / 40	3	21
<b>132 - 132L - 160L</b>	8	55	12	38
<b>160</b>	8	55	12	38
<b>200 - 200L</b>	15	65	24	45

**TABLE FOR THE CHOICE OF THE THERMIC CIRCUIT BREAKER FOR MOTOR PROTECTION AND FOR KNOWING THE POWER NECESSARY TO VENTILATORS**

The thermic circuit breaker must be adjusted for a current that exceeds the rated current of 15%. Absorption data, as regards motors with main power supply 240-415-440-460, can be approximately calculated in a proportional way from the current of each respective motor with main supply 380V.

MOTOR POWER		MEC SIZE	NOM. CURRENT		FANS POWER	
HP	KW		220VAC <b>A</b>	380VAC <b>A</b>	AXIAL <b>VA</b>	SCROLL <b>VA</b>
0.15	0.11	63	1.5	0.9	20	
0.25	0.18	71	1.9	1.2	20	
0.5	0.37	80	2.9	1.7	20	
1	0.75	90	6	3.5	25	100
2	1.5	100	11	7	50	100
2.5	1.85	90L	15	8.5	*	100
3	2.2	112	16	9	50	100
4	3	112L	20	12	50	100
6	4.5	132	33	19	50	100
7.5	5.5	132L	39	24	50	100
10	7.5	160	49	29	100	200
14	10.5	160L	68	39	*	200
18	13.2	200	90	55	*	1000 Trif.
25	18.5	200L	110	65	*	1000 Trif.
30	22	250	130	75	*	1000 Trif.

## INSTRUCTIONS FOR THE CONNECTION

Connection Diagram 1

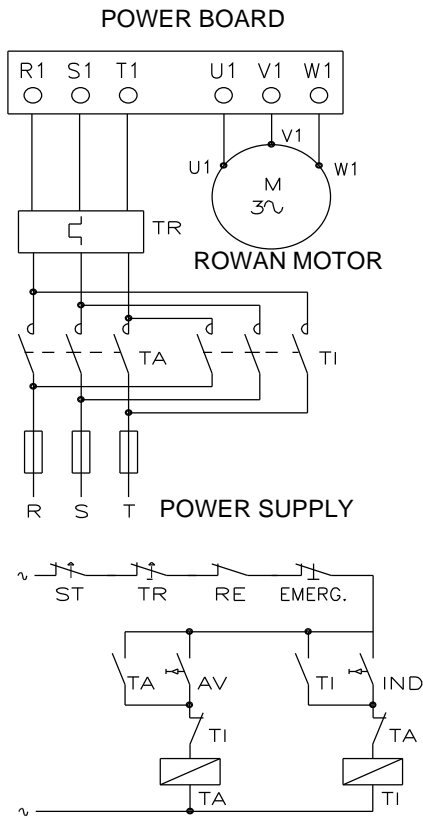

CONTROL BOARD

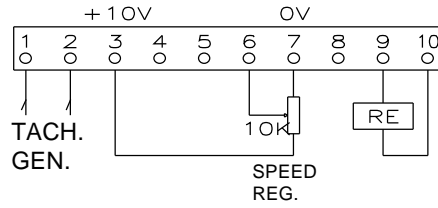

VERSION WITH 3 WIRE SPEED POT.

CONTROL BOARD

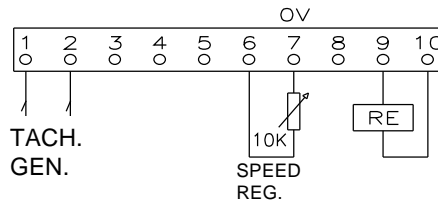

VERSION WITH 2 WIRE SPEED POT.  
(MICRO S1 CLOSED)

### SPEED CONTROL IN 2 ROTATION SENSES BY MEANS OF POTENTIOMETER:

It is the typical connection diagram of drive cod. 290.

Speed regulation is performed by means of an external 3 wire potentiometer. With potentiometer cursor on terminal 7 (0V), the motor does not rotate; whereas with the cursor on terminal 3 (+10VDC), the motor runs at the max preset speed. The potentiometer in this case is 10Kohm but can also have higher or lower values provided that a minimum resistance of 3Kohm is present between terminals 3-7. In the same way one must calculate the value of possible potentiometers that are used in parallel, for the commutation of different speeds.

The group of emergencies with opening contacts includes: the thermic circuit breaker (TR) set to the value of motor max current - the thermic probe (ST), which controls the temperature of the windings - the relay of phase lack emergency (RE). In any case, even if relay RE is not connected, the lack of one phase immediately removes the power from the motor statically, switches led L1 (RUN) off, and switches led L3 (phase lack/low voltage) on. This intervention is self retaining and then to reset it, it is necessary to remove the power from drive cod. 290; it is anyway evident that the electromechanic switching off of remote control switches is more reliable in emergency condition, above all in case of bad functioning of drive cod. 290

### SELECT MICROSWITCHES IN THE FOLLOWING WAY:

- S1 Open (speed regulation with 3 wire potentiometer)
- S2 Choose the desired range of ramps (open 0,02 sec - 2 sec / closed 0,25 sec - 25 sec)
- S3 Open in case of 2 pole motor  
Closed in case of 4 - 6 pole motor

In case of 6 pole motor it is necessary to adjust the max speed with trimmer P3. With speed potentiometer set to max speed, rotate P3 anticlockwise till one measures a direct voltage of approximately 5,7VDC from the tachometer generator, corresponding to a max speed of 800rpm.

- S5-S6 Closed
- S4-S7 Open

CONTROL BOARD

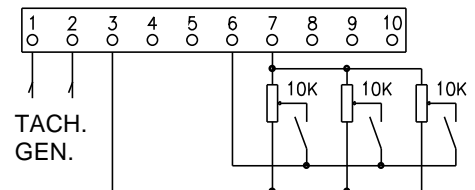

## SPEED REGULATION WITH REFERENCE FROM D.C. SIGNAL:

Speed regulation of cod. 290 can be performed, besides the typical potentiometer, by applying a D.C. signal  $0 \div 10V$  2 mA to terminals 6 - 7.

This signal may come (according to requirements) from ROWAN interface cards or from other commercial equipments such as PLC, logics, computer etc.

This connection can be made directly because all drive input commands are galvanically separated from the power.

With 0VDC input, adjust trimmer P5 (min. speed) so that the motor does not run; with +10VDC input, the motor runs at the max preset speed.

## CONTROL BOARD CONNECTION FOR D.C. SIGNAL INPUT

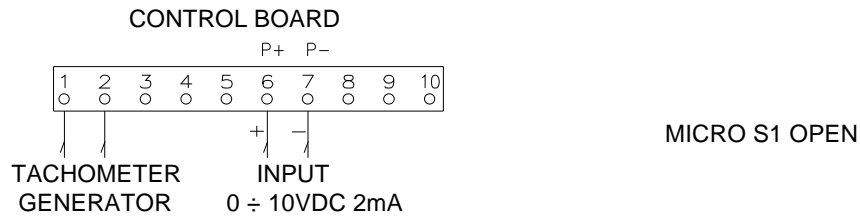

## CONNECTION DIAGRAM 2

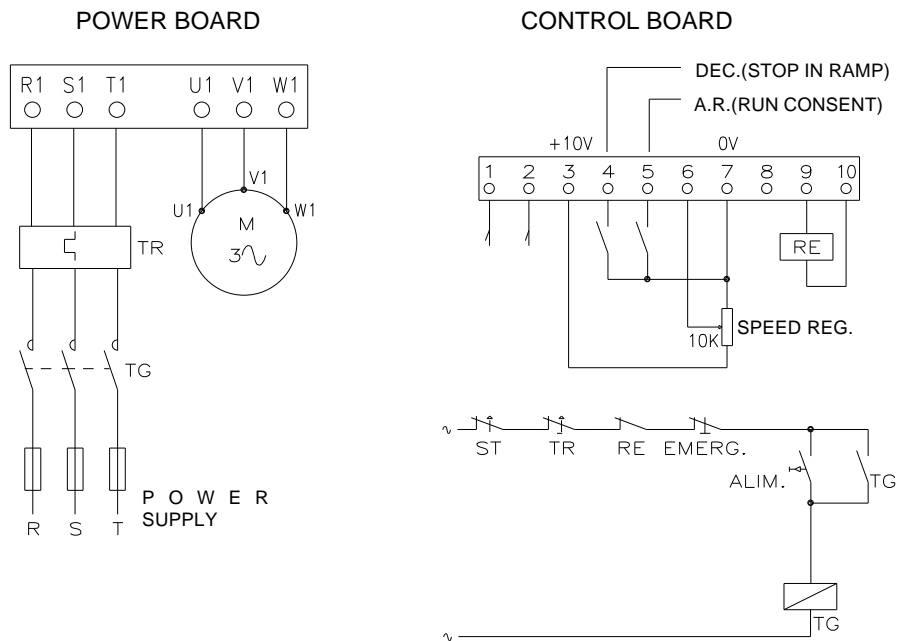

## SPEED CONTROL IN ONE ROTATION SENSE WITH RUN/STOP IN RAMP STATIC COMMAND

It is a diagram used in case of one direction movement with frequent starts and stops. By using AR and STOP IN RAMP inputs it is possible to control motor rotation avoiding the command of remote control switches and the flaming of contacts. Power is applied to the drive by means of a line push-button which energizes TG.

By closing AR contact between terminals 5-7, the voltage is immediately removed from the motor, ramps are set to zero and led L1 ( RUN ) is switched off.

By opening AR contact the motor starts with acceleration to max preset speed, with a ramp time adjustable with trimmer P2 acceleration.

With AR contact open, the closing of stop in ramp contact (deceleration), causes the ramp down of motor to 0 revolution, with a ramp time adjustable with trimmer P1 deceleration.

The re-opening of stop in ramp contact enables the restart of the motor with acceleration ramp to max speed.

In any case, the regulation of speed potentiometer or signal D.C. is subject to acceleration - deceleration ramps set with trimmers P1 - P2.

As written before, the controlled deceleration ramp operates with braking loads with irreversible systems but it is ineffective with inertial loading.

Microswitch selection is the same as that of connection diagram 1.

### CONNECTION DIAGRAM 3

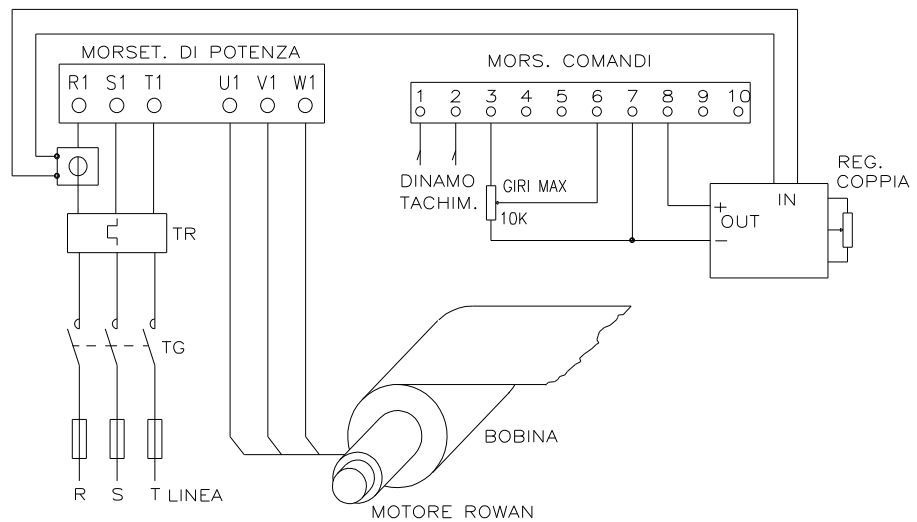

### SPEED / TORQUE COMBINED CONTROL:

This diagram is used in case ROWAN motor is employed as winder/unwinder.

Max speed is set with speed potentiometer, whereas motor torque is regulated by means of an external interface card, which refers to the current absorbed by the motor by means of an amperometric transformer.

The external interface card controls max torque through the connection to terminals 7-8 of drive cod. 290.

The kind of card to couple with cod. 290 is chosen according to the application requirements of winder/unwinder systems. In the case of winder, microswitches must be selected as for diagram 1. The same for unwinder with the exception of S5 open and S4 closed.

### CONNECTION DIAGRAM 4

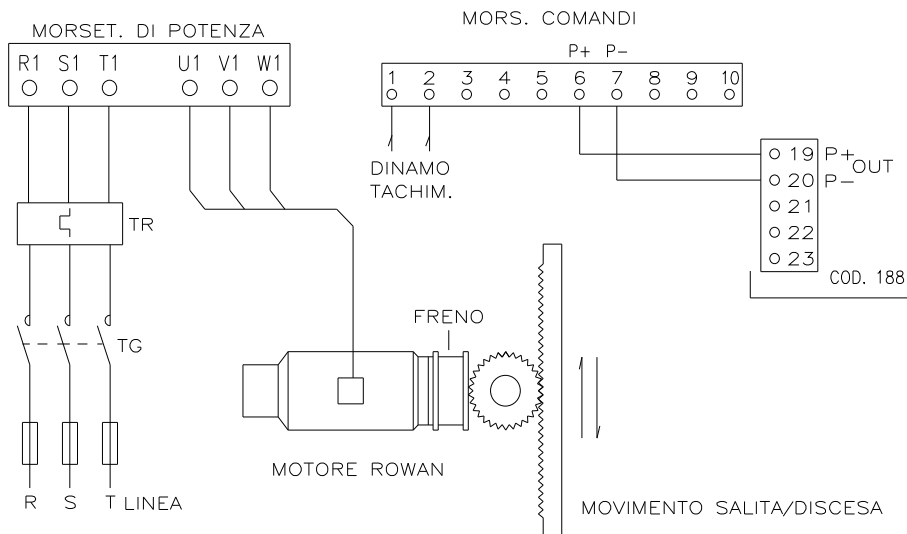

### SPEED CONTROL OF UP AND DOWN MOVEMENT WITH UNBALANCED LOADING:

Diagram used for lifting equipments (loaders - unloaders).

By means of interface card cod. 188, drive cod. 290 receives up and down movement commands at different speeds, synchronized with brake command. When card cod. 188 supplies terminals 6(P+) and 7(P-) with +10VDC, the motor lifts up the load at max preset speed; when card cod. 188 supplies terminals 6 and 7 with -10VDC, the motor lets the load go down, keeping it at the max preset speed. During the down movement, the motor keeps the load at the preset speed but it can not push it. This system can function if the loading is so unbalanced that it can reach and exceed, of course in a very short time, the max speed during the down movement.

In this case acceleration / deceleration ramps are adjusted with the trimmers of drive cod. 188, whereas the trimmers of drive cod. 290 must be adjusted completely anticlockwise so that drive reaction is very fast.

### MICROSWITCH SELECTION:

S1-S2-S5-S7 open

S4-S6 closed

S3 open for 2 pole motor - Closed for 4-6 pole motor

## INSTRUCTIONS FOR THE SETTING UP

First of all, connect the 3 voltage jumpers according to the mains supply voltage as follows:

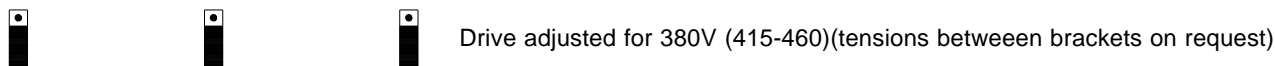
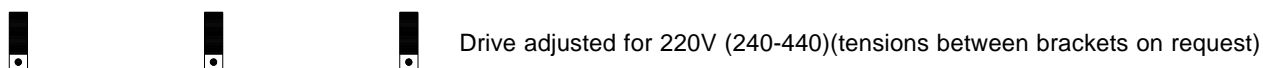

Select micro S3 according to the polarity of the motor:

2 pole motor / microswitch S3 open  
4-6 pole motor / microswitch S3 closed

In case of 6 pole motor, it is necessary in addition to rotate trimmer P3 anticlockwise, till the tachometer generator generates approximately 5,7VDC, with potentiometer or D.C. signal set to max.

Select the desired range of acceleration and deceleration ramps:

Micro S2 open: Regulation range of trimmer P1 deceleration min. 0,02 sec.- max 2 sec. Regulation range of trimmer P2 acceleration min. 0,02 sec - max 2 sec.

Micro S2 closed: Regulation range of trimmer P1 deceleration min. 0,25 sec - max 25 sec. Regulation range of trimmer P2 acceleration min. 0,25 sec. - max 25 sec.

Select the kind of external speed control:

- External 3 wire potentiometer connected to terminals 3-6-7: microswitch S1 open, standard value 10Kohm, minimum value 3Kohm.

In this case potentiometer regulation as related to motor speed is linear.

With cursor 6 on terminal 7 (6-7 0VDC), the motor does not rotate; with cursor 6 on terminal 3 (6-7 10VDC), the motor runs at max speed.

- External 2 wire potentiometer connected to terminals 6-7: microswitch S1 closed, fixed value 10Kohm. In this case potentiometer regulation as related to speed is not linear. With potentiometer 0ohm, the motor does not rotate; with potentiometer 10Kohm, the motor runs at max speed.

- D.C. signal input 0 ÷ 10VDC 2 mA to terminals 6(P+) and 7(P-): micro S1 open

Motor speed is proportional to the value of input signal.

With 0VDC the motor does not rotate; with 10VDC the motor runs at max speed.

Connect the drive and select the other microswitches as specified in the preceding examples:

Standard selection: S4 - S7 open / S5 - S6 closed

Besides the signal of the tachometer generator present on terminals 1-2, it is necessary to connect to motor control board:

- the ventilator to terminals 3 - 4

- the thermic probe to terminals 5 - 6

The single phase ventilator must be supplied with 220VAC 50/60Hz; it must not depend on motor RUN command but on the general panel. In this way it is possible to cool the motor also when it does not run.

In case of motors with 3 phase cochlea ventilator, the connection is made directly at the base of the ventilator.

The thermic probe is a N.C. contact that must be connected in series with emergencies. It is directly inserted in the motor windings and opens if the temperature approaches the safety limit for windings tropicalized in H class.

Set the potentiometer or D.C. signal to speed 0. Apply power to the drive, the motor must not run. The lighting of led L2 (power on) indicates the presence of power on control circuits, the lighting of led L1 RUN indicates that there is the consent for motor running.

Rotate the potentiometer or increase D.C. signal, the motor must follow the regulation up or down with the preset acceleration/deceleration ramps.

Verify the reaching of max speed. If necessary adjust the setting of max speed with trimmer P3. Be careful not to exceed max regulation, because there may be a motor overabsorption even without loading. If there is a motor overabsorption at max speed, rotate trimmer P3 anticlockwise till motor absorption is equal to the absorption measured at an intermediate speed.

In any case verify that the absorptions are balanced on all three phases and of course that they do not exceed motor ratings. In case the motor does not follow the regulation of the potentiometer or D.C. signal, verify, besides the position of micro S4 - S5, the connection of tachometer generator and the presence of voltage on terminals 1-2, both on motor service board and on drive control board. In any case, while the motor runs, the presence of tachometer generator is signalled by the lighting of led L4; (L4 is off if tachometer generator is absent or the motor does not run). If one desires to

set a minimum speed different from standard (0 rev.), one can do it by adjusting trimmer P6.

Drive cod. 290 is provided with a protection device to command an emergency relay in case of phase lack. This relay of type 24VDC max 50 mA can be connected to terminals 9 - 10 and can be used to switch off RUN remote control switch in emergency situations; even if it is not used, in case of phase lack, the drive statically removes the voltage from the motor, switches led L1 RUN off and lights up phase lack led L3. This intervention is self-retaining and it is necessary to remove the power from the drive to reset it. In this case, before restarting, it is obviously necessary to verify main supply voltage.

Drive cod. 290 has a reset time of 0,5 sec., which is enough to guarantee a correct restart with acceleration ramp, any time power is applied to the drive.

As already mentioned before (diagram n° 2), in case of frequent operations it is advisable not to remove the power from the drive and to command it statically with STOP IN RAMP or A.R. (RUN consent) contacts.

If, while the motor runs, there are oscillations due to the particular kind of loading or mechanic transmission, it is possible to eliminate them by rotating trimmer P6 (stability) clockwise. If one desires a more soft and fast response of the motor, close micro S7.

Whenever a great speed control precision is necessary, open micro S6; in this case there is a minimum speed variation from empty to full load and the motor is able to furnish the nominal torque even at low speed (2 - 3 rev.), with the disadvantage of slowing the time of drive response; in this case micro S7 must remain open.

## USAGE INSTRUCTIONS FOR CORRECT FUNCTIONING

Drive Cod. 290 is provided only with a protection device for phase lack and three fuses (0,5A rapid) for control circuit; as for amperometric protections, it is necessary to provide externally with fuses against short circuit and with thermic circuit breakers of the correct rating according to motor max current (see tables).

It is necessary to use screened cable for the following connections: potentiometer - analogic command signal - tachometer generator - torque control signal - A.R. and deceleration commands. The screens must be connected to earth and not to drive negative pole (0V). Besides this, do not connect the drive negative pole to earth. Avoid, if possible, placing the drive near the power cabling or big transformers. Use relays for low current operation, for A.R. (RUN consent) and STOP IN RAMP commands or for selecting potentiometers or D.C. signals; absolutely avoid using the auxiliary contacts of remote control switches for this kind of operations.

Drives cod. 290 work correctly with cubicle temperature ranging from -15°C to +60°C. Higher temperatures could cause working anomalies and, if excessive, breakdown. It is therefore advisable to place them far from heat sources and ventilate the cubicles when the ambient is too hot.

## STANDARD ADJUSTMENT

Drives cod. 290 leave ROWAN ELETTRONICA tested and adjusted in the following way:

- 380VAC mains voltage supply
- Connection for 3 wire speed potentiometer - S1 open
- Range of ramps - min. 0,02 sec. - max 2 sec. / S2 open
- 4 pole motor - S3 closed
- Polarity rectifying circuit activated - S5 closed/S4 open
- S7 open - S6 closed

## SETTING

Minimum speed 0rpm

Max speed 1400rpm

Acceleration/deceleration ramps 2 sec.

# BLOCK DIAGRAM

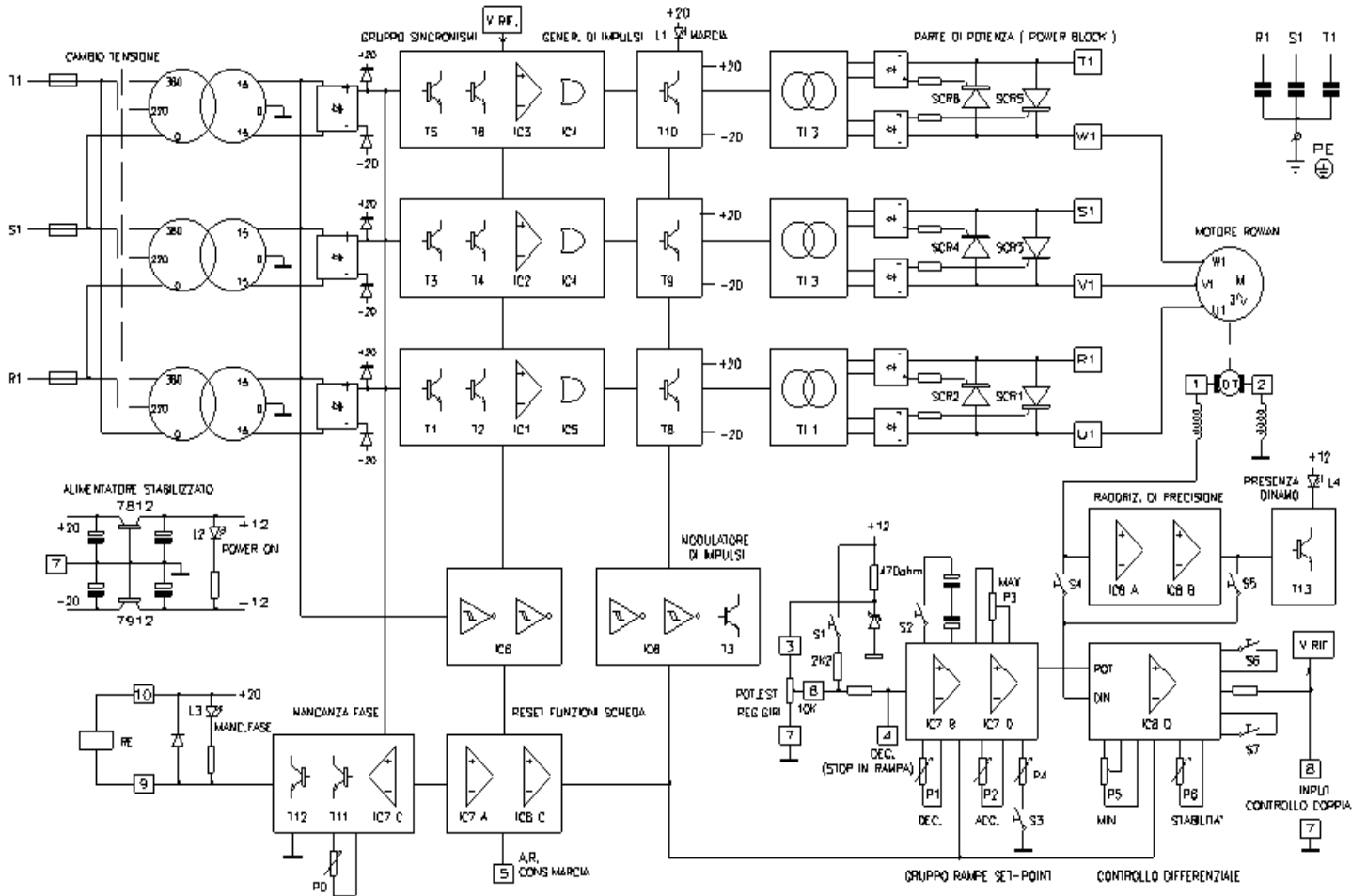

# CIRCUIT SERIGRAPHY

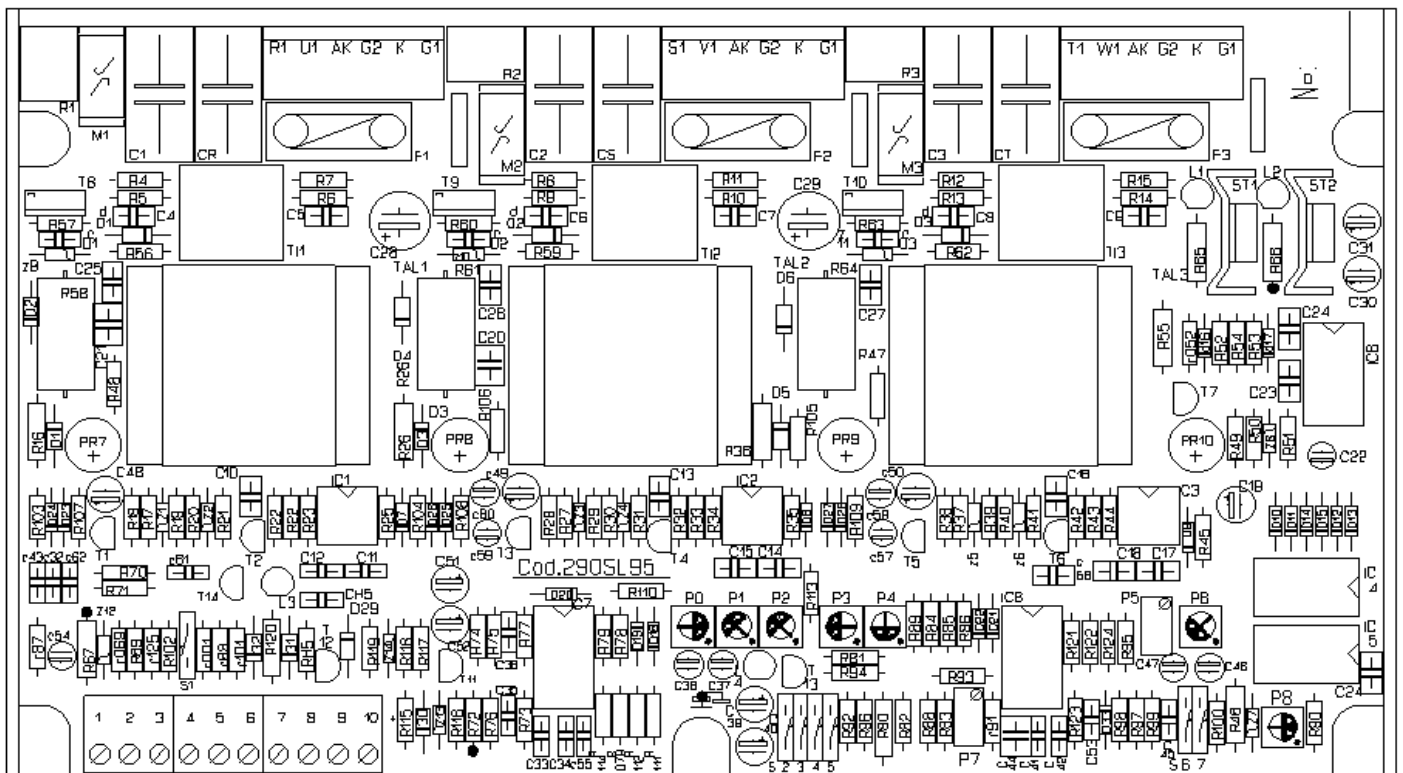

## TABLE OF CONTENTS

General characteristics - Max overall sizes - Operating principle .....	page 2
Microswitches/Leds/Trimmers serigraphy - Trimmer description - Control board description .....	page 3
Microswitch description - Visualizations description Instruction for the connection with ROWAN motors - Power board connection .....	page 4
Range of powers of drives cod. 290 Motor service board connection - Brake connection (for motor with brake) .....	page 5
Tables for the choice of the thermic circuit breaker and for knowing the powers absorbed by brake and ventilator .....	page 6
Application diagrams .....	pages 7 - 8 - 9
Instructions for the setting up .....	page 10
Usage instructions for correct functioning - Standard adjustment and setting .....	page 11
Block diagram Circuit serigraphy .....	page 12

ROWAN ELETTRONICA Srl declines any responsibilities for possible inexactitudes in this instruction manual due to printing, transcription or translation errors; besides, ROWAN ELETTRONICA Srl reserves the right to make, if necessary and without notice, any variations needed for a better working of the product.  
As concerns the data and the characteristics mentioned in this manual, a max. tolerance of  $\pm 10\%$  is allowed.



